

**Road Planning and Design Manual  
Edition 2: Volume 3**

**Supplement to Austroads Guide to Road Design  
Part 5B: Drainage – Open Channels, Culverts and  
Floodway Crossings**

**January 2024**



## Copyright

© The State of Queensland (Department of Transport and Main Roads) 2024.

## Licence



This work is licensed by the State of Queensland (Department of Transport and Main Roads) under a Creative Commons Attribution (CC BY) 4.0 International licence.

## CC BY licence summary statement

In essence, you are free to copy, communicate and adapt this work, as long as you attribute the work to the State of Queensland (Department of Transport and Main Roads). To view a copy of this licence, visit: <https://creativecommons.org/licenses/by/4.0/>

## Translating and interpreting assistance



The Queensland Government is committed to providing accessible services to Queenslanders from all cultural and linguistic backgrounds. If you have difficulty understanding this publication and need a translator, please call the Translating and Interpreting Service (TIS National) on 13 14 50 and ask them to telephone the Queensland Department of Transport and Main Roads on 13 74 68.

## Disclaimer

While every care has been taken in preparing this publication, the State of Queensland accepts no responsibility for decisions or actions taken as a result of any data, information, statement or advice, expressed or implied, contained within. To the best of our knowledge, the content was correct at the time of publishing.

## Feedback

Please send your feedback regarding this document to: [tmr.techdocs@tmr.qld.gov.au](mailto:tmr.techdocs@tmr.qld.gov.au)

## Relationship with Austroads Guide to Road Design – Part 5B (2023)

The Department of Transport and Main Roads has, in principle, agreed to adopt the standards published in the Austroads *Guide to Road Design (2023) Part 5B: Drainage – Open Channels, Culverts and Floodway Crossings*.

When reference is made to other parts of the Austroads *Guide to Road Design*, Austroads *Guide to Traffic Management* or the Austroads *Guide to Road Safety*, the reader should also refer to Transport and Main Roads related manuals:

- *Road Planning and Design Manual (RPDM)*, and
- *Traffic and Road Use Management Manual (TRUM)*.

Where a section does not appear in the body of this supplement, the Austroads *Guide to Road Design – Part 5B* criteria is accepted unamended.

This supplement:

1. has precedence over the Austroads *Guide to Road Design – Part 5B* when applied in Queensland
2. details additional requirements, including accepted with amendments (additions or differences), new or not accepted, and
3. has the same structure (section numbering, headings and contents) as Austroads *Guide to Road Design – Part 5B*.

The following table summarises the relationship between the Austroads *Guide to Road Design – Part 5B* and this supplement using the following criteria:

Accepted	Where a section does not appear in the body of this supplement, the Austroads <i>Guide to Road Design – Part 5B</i> is accepted.
Accepted with amendments	Part or all of the section has been accepted with additions and/or differences.
New	There is no equivalent section in the Austroads Guide.
Not Accepted	The section of the Austroads Guide is not accepted.

Austroads Guide to Road Design – Part 5B	RPDM relationship
<b><u>1 Introduction</u></b>	
1.1 Purpose	Accepted
1.2 Scope of this Part	Accepted
1.3 Road Safety	Accepted
<b><u>2 Open Drains and Channels</u></b>	
2.1 Introduction	Accepted with amendments
2.2 General Considerations	Accepted
2.3 Fundamentals of Open Channel Flow	Accepted with amendments
2.4 Erosive Velocities in Natural Streams	Accepted
2.5 Backwater	Accepted with amendments
2.6 Tailwater Levels	Accepted

<b>Austrroads Guide to Road Design – Part 5B</b>		<b>RPDM relationship</b>
2.7	Open Channel Design	Accepted with amendments
2.8	Grassed Channels	Accepted
2.9	Channels Lined with Hard Facings	Accepted
2.10	Channel Drops	Accepted
2.11	Baffle Chutes	Accepted
2.12	Edge Drains and Median Drains	Accepted with amendments
2.13	Table Drains and Table Drain Blocks	Accepted with amendments
2.14	Batter Drains and Chutes	Accepted
2.15	Catch Drains and Catch Banks	Accepted with amendments
2.16	Worked Examples	Accepted
<b>3 Culverts</b>		
3.1	Introduction	Accepted with amendments
3.2	Information Required	Accepted
3.3	Culvert Location	Accepted with amendments
3.4	Culvert Type	Accepted with amendments
3.5	Culvert Size	Accepted with amendments
3.6	Structural Requirements	Accepted with amendments
3.7	Hydraulic Design Considerations	Accepted with amendments
3.8	Typical Culvert Operating Conditions	Accepted
3.9	Hydraulic Calculations	Accepted with amendments
3.10	Design Procedures	Accepted with amendments
3.11	Blockage of Culverts	Accepted with amendments
3.12	Consideration of Large or Extreme Events	Accepted
3.13	Culvert Outlet Protection	Accepted with amendments
3.14	Culvert End Treatments	Accepted with amendments
3.15	Worked Examples	Accepted
3.16	Culverts in Expansive Soil Areas	New
<b>4 Floodway Crossings</b>		
4.1	Introduction	Accepted with amendments
4.2	Design Considerations	Accepted with amendments
4.3	Hydraulic Design	Accepted with amendments
4.4	Time of Submergence and Closure	Accepted with amendments
4.5	Floodway Damage	Accepted
4.6	Floodway Crossing Profiles	Accepted
4.7	Floodway Crossing Protection Examples	Accepted
4.8	Worked Examples	Accepted
<b>References</b>		
	References	Accepted with amendments
<b>Appendices</b>		
Appendix A	Vegetal Retardance Curves	Accepted
Appendix B	Inlet and Outlet Control Nomographs	Accepted

<b>Austrroads Guide to Road Design – Part 5B</b>		<b>RPDM relationship</b>
Appendix C	Velocity and Critical Depth	Accepted
Appendix D	Culvert Capacity	Accepted
Appendix E	Solving Manning's Equation	Accepted
Appendix F	Structural Assessment/Decision Process	New
Appendix G	Structural Failure Risk Assessment	New
Appendix H	Culvert Wingwall Length Calculations	New

### Departmental contacts

- Hydraulics and Flooding, Engineering and Technology Branch, Transport and Main Roads email [TMRH&FProjects@tmr.qld.gov.au](mailto:TMRH&FProjects@tmr.qld.gov.au).
- Structures, Transport and Main Roads email: [roaddesignstandards@tmr.qld.gov.au](mailto:roaddesignstandards@tmr.qld.gov.au). Road Design Standards will direct this email to the correct area for reply.
- General enquiries or feedback email [roaddesignstandards@tmr.qld.gov.au](mailto:roaddesignstandards@tmr.qld.gov.au).

# Contents

- Departmental contacts.....iii**
- 2 Open Drains and Channels.....1**
- 2.1 Introduction ..... 1
  - 2.1.1 *Definition and Use* .....1
  - 2.1.4 *Types of Open Drains* .....1
- 2.3 Fundamentals of Open Channel Flow ..... 1
  - 2.3.1 *Stream Dynamics* .....1
  - 2.3.3 *Fundamental Equations* .....1
- 2.5 Backwater ..... 3
  - 2.5.2 *Downstream Tributary* .....3
- 2.7 Open Channel Design ..... 4
  - 2.7.1 *Design Methodology*.....4
- 2.12 Edge Drains and Median Drains ..... 4
  - 2.12.1 *Design of Edge and Median Drainage* .....4
- 2.13 Table Drains and Table Drain Blocks ..... 5
  - 2.13.1 *Table Drains* .....5
  - 2.13.2 *Table Drain Blocks* .....5
- 2.15 Catch Drains and Catch Banks..... 5
  - 2.15.1 *Catch Drains*.....5
- 3 Culverts.....5**
- 3.1 Introduction ..... 5
- 3.3 Culvert Location ..... 6
  - 3.3.3 *Non-hydraulic Considerations* .....7
- 3.4 Culvert Type..... 9
  - 3.4.1 *Culvert Shape*.....9
  - 3.4.2 *Materials*..... 10
- 3.5 Culvert Size..... 11
  - 3.5.1 *Minimum Culvert Size Allowable* ..... 11
  - 3.5.2 *Other Sizing Considerations*..... 11
- 3.6 Structural Requirements ..... 11
  - 3.6.1 *Design Loads*..... 12
  - 3.6.2 *Existing Culverts*..... 12
  - 3.6.3 *Space between Pipes in Multiple-Barrel Culverts* ..... 14
  - 3.6.4 *Cover*..... 14
  - 3.6.5 *Structural requirements for new structures* ..... 14
  - 3.6.6 *Reinforced concrete pipes*..... 15
  - 3.6.7 *Fibre-reinforced concrete pipes*..... 15
  - 3.6.8 *Reinforced concrete box culverts*..... 16
  - 3.6.9 *Reinforced concrete slab deck culverts*..... 16
  - 3.6.10 *Corrugated steel pipes* ..... 16
  - 3.6.11 *Plastic flexible pipes* ..... 18
  - 3.6.12 *Aluminium culverts* ..... 18
  - 3.6.13 *Splay pipes* ..... 19
  - 3.6.14 *Other structural aspects* ..... 19
- 3.7 Hydraulic Design Considerations..... 19
  - 3.7.2 *Outlet Velocity* ..... 19
  - 3.7.4 *Siltation and Blockage*..... 19
  - 3.7.6 *Tailwater (TW)*..... 19

3.9	Hydraulic Calculations .....	20
3.10	Design Procedures .....	21
3.11	Blockage of Culverts .....	24
3.13	Culvert Outlet Protection.....	25
3.13.1	<i>Flap Gates (Tides and Floods)</i> .....	25
3.14	Culvert End Treatments .....	25
3.14.1	<i>General</i> .....	26
3.14.2	<i>Slope Faced</i> .....	26
3.14.3	<i>Traversable Endwalls</i> .....	26
3.16	Culverts in Expansive Soil Areas.....	26
3.16.1	<i>Expansive Soil Potential</i> .....	27
3.16.2	<i>Postulated Mechanism of Distress</i> .....	28
3.16.3	<i>Standard Drawings</i> .....	28
3.16.4	<i>Amended Design Procedure</i> .....	29
3.16.5	<i>Foundation Investigation</i> .....	29
3.16.6	<i>Options for the Control of Distress in Culverts</i> .....	31
<b>4</b>	<b>Floodway Crossings</b> .....	<b>32</b>
4.1	Introduction .....	32
4.2	Design Considerations.....	33
4.2.1	<i>General</i> .....	33
4.2.2	<i>Culvert Dimensions and Design Considerations for Culverts Under the Floodway Crossing</i> 33	
4.3	Hydraulic Design.....	34
4.4	Time of Submergence and Closure .....	34
4.4.1	<i>Introduction</i> .....	34
4.4.3	<i>Time Required to Reopen the Road after Flood Closures</i> .....	34
	<b>References</b> .....	<b>36</b>
	<b>Appendix F – Structural Assessment / Decision Process</b> .....	<b>38</b>
	<b>Appendix G – Structural Failure Risk Assessment</b> .....	<b>39</b>
	<b>Appendix H – Culvert Wingwall Length Calculations</b> .....	<b>41</b>

## Tables

Table 3.4.1	– Culvert types for different conditions .....	10
Table 3.16.5	– Required tests .....	30
Table G-1	– Risk rating – major .....	39
Table G-2	– Risk rating – major .....	39
Table G-3	– Risk rating – W = 675 to 1200 mm.....	39
Table G-4	– Risk rating – W = 1350 to 1800 mm* .....	40
Table H-1	– Culvert description and symbols.....	41

## Figures

Figure 2.3.3	– Streams in Queensland.....	2
--------------	------------------------------	---

Figure 3.3 – Skew angle / skew number .....	7
Figure 3.3.3 – Koala fencing.....	8
Figure 3.6.8 – Slab link box culvert under construction .....	16
Figure 3.6.10(a) – Corrugated steel pipes.....	17
Figure 3.6.10(b) – Culvert lining details.....	18
Figure 3.9 – Box Culverts with riprap .....	21
Figure 3.16(a) – Longitudinal cracking of apron failure .....	26
Figure 3.16(b) – Vertical displacement of apron failure .....	27
Figure 3.16.3 – Failure mechanism of base slabs in expansive soils .....	29
Figure 4.1 – Little Annan River floodway crossing .....	33
Figure 4.4.3 – Typical deck level / time of submergence relationship .....	35
Figure F-1 – Pre-2004 culvert – structural assessment / decision process .....	38
Figure G – Structural risk assessment – minor culverts.....	40
Figure H – Culvert wingwall length calculations .....	42



## 2 Open Drains and Channels

### 2.1 Introduction

#### 2.1.1 Definition and Use

##### Addition

Open channels have the advantages of continuous collection of surface runoff, and where the system surcharges, general shallow flow is the most likely outcome rather than more concentrated flooding at upstream inlets of the closed drainage system.

This supplement focuses on the analysis and design of channels, smaller streams and creeks. Assessment of larger streams, creeks, rivers and floodplains is complex and should be referred to the departments Hydraulics and Flooding Unit, Engineering and Technology Branch or a suitably prequalified consultant. The *Hydrologic and Hydraulic Modelling* Guideline should be referred to when dealing with cross-drainage and flooding issues.

#### 2.1.4 Types of Open Drains

##### Addition

Open channels may be constructed to specified criteria:

- as part of the road drainage system where space within the road reserve is sufficient to provide for open channels
- as diversion channels, especially where the road is being constructed generally along the line of a watercourse and severs one or more meanders in the stream. Care must be exercised as shortening of the stream will increase the gradient and hence velocity, which may induce scouring and also prevent the upstream passage of fish, and
- from the outlets of culverts or drainage systems.

### 2.3 Fundamentals of Open Channel Flow

#### 2.3.1 Stream Dynamics

##### Addition

The Manning's roughness coefficient is not dimensionless. This is (s/m<sup>1/3</sup>) when using the (SI) system.

#### 2.3.3 Fundamental Equations

##### Addition

For natural channels, a comparison may be made with the photographs in Figure 2.3.3. Appendix C of *Natural Channel Design Guidelines* shows photos and tables of Queensland streams and their recommended Manning's Coefficients.

**Figure 2.3.3 – Streams in Queensland**



n = 0.03



n = 0.04–0.045



n = 0.05–0.06



n = 0.07



n = 0.08

Notes:

1. Increase in 'n' value with an increase in grass, weeds, shrubs and trees.
2. In general, growth of trees in photographs tends to look denser than when seen on a site inspection.
3. Except for n = 0.03, roughness is for bank full flood heights and/or floods in upper branches of the trees.
4. Use photographs with caution. Use in conjunction with Table 2.2 of the Austroads *Guide to Road Design – Part 5B*.
5. It should be noted that Manning's n values decrease with increasing flow depth. As such, roughness values provided in charts such as Chow (1959) or Brisbane City Council (BCC) (2003) may need to be adjusted for channels with shallow flow depths. Maximum flow velocity and hydraulic capacity requirements for a channel may need to be analysed for different roughness values. Section 9.3.5 of Queensland Urban Drainage Manual (QUDM) is accepted for these cases.

## 2.5 Backwater

### 2.5.2 Downstream Tributary

#### Addition

If the crossing is located on a stream which joins another watercourse (larger or smaller) downstream, other issues need to be considered.

As the two open channels have different catchment sizes, they will peak at different times. The combined flow at their junction needs to be assessed.

In this case, two situations need to be considered:

- major flood on tributary with limited flow in the mainstream, and
- major flood on the mainstream and limited flow in the tributary.

Both cases need to be analysed to provide an understanding of the potential flood conditions at the road. The risk of coincidental flooding in the two streams needs to be considered to determine the combined risk of flooding. Depending on the relative sizes of the two streams, it may not be realistic to expect floods to occur together in the two streams.

If the assumption of full or partial dependence has significant impacts on the design of the infrastructure, a joint probability analysis in accordance with Book 4, Chapter 4 of *Australian Rainfall and Runoff* (ARR) is recommended to determine the required design levels of the infrastructure.

## **2.7 Open Channel Design**

### **2.7.1 Design Methodology**

#### Addition

Freeboard is the additional height of channel required above the height of the design flow. This allows for inaccuracies in data used in calculation and possible surcharge due to silt / debris build up and/or grass growth in the channel because of delayed maintenance of the channel.

## **2.12 Edge Drains and Median Drains**

### **2.12.1 Design of Edge and Median Drainage**

#### Addition

- Median longitudinal drainage will usually have a concrete lined invert to assist maintenance and reduce the risk of errant vehicles rolling after hitting ruts caused by tractor mowing.
- The pavement runoff can be calculated using the Rational Method Formula, but consideration must be given to the different runoff coefficients for pavement and the median surfaces.
- The minimum grade for unlined drains is 0.5% and 0.2% for lined drains; however, 0.3% may be regarded as the minimum practical slope for construction. The base of a trapezoidal drain shall have a crossfall of 3% as required by Section 2.13.1 of Austroads *Guide to Road Design* (AGRD) – *Part 5B*. It is preferred that the minimum width of base shall be the wider of 1 m, or machine width (refer to local departmental office). Where constrained by space, a vee-invert is permissible. Where a concrete invert is necessary due to minimum grade requirements, the invert shall comprise a Type 22 section (Refer Transport and Main Roads Standard Drawing SD1033) or equivalent, to be located at the lowest point within the trapezoidal section. Additional lining may be required if erosion potential exists.

## **2.13 Table Drains and Table Drain Blocks**

### **2.13.1 Table Drains**

#### Addition

1. Parabolic drains can also be used, although these are difficult to construct / maintain.
2. Designers must check the hydraulic characteristics of flows in table drains for the design conditions. This is to ensure that sufficient capacity is provided, and the table drain is not susceptible to erosion. Determination of depth and velocity of flow within the table drain can be undertaken using Manning's Equation.
3. The minimum grade for unlined drains, including table drains, is 0.5% and 0.2% for lined drains; however, 0.3% may be regarded as the minimum practical slope for construction. The base of a trapezoidal drain shall have a crossfall of 3% as required by Section 2.13.1 of AGRD – *Part 5B*. It is preferred that the minimum width of base shall be the wider of 1 m, or machine width (refer to local Transport and Main Roads office). Where constrained by space, a vee-invert is permissible. Where a concrete invert is necessary due to minimum grade requirements, the invert shall comprise a Type 22 section (refer SD1033) or equivalent, to be located at the lowest point within the trapezoidal section. Additional lining may be required if erosion potential exists.

### **2.13.2 Table Drain Blocks**

#### Addition

A marker post (refer SD1358) should be placed on / adjacent to table drain blocks to alert maintenance personnel of their existence.

## **2.15 Catch Drains and Catch Banks**

### **2.15.1 Catch Drains**

#### Addition

These devices are generally located no closer than 2 m from the edge of the cuttings in order to minimise possible undercutting of the top of the batter.

## **3 Culverts**

### **3.1 Introduction**

#### Addition

Culverts are important hydraulic structures used to convey water across a road corridor or in one of a range of other situations. Culverts must be designed to convey this flow in an acceptable way, considering the hydraulic conditions and the required performance (level of flood immunity) of the road. Environmental and/or other requirements may also need to be considered / incorporated, depending on the specific circumstances.

In particular, the provision of fauna passage, including fish movement, may need to be incorporated into the design. In certain situations (typically where specified by an environmental assessment document), culvert designs will have special requirements to allow the passage of fish or terrestrial fauna.

Other uses for culvert structures may include pedestrian / cyclist movement, vehicular movement (including rail / cane rail), fauna crossing or stock underpass.

While the requirements will differ depending on whether passage is to be catered for, all will require a clear distinction between wet and dry passageways.

The size requirements for passage, as well as hydraulic requirements, need to be considered, and the culvert sized appropriately to meet both of these requirements.

If no passage is to be provided, then the culvert is designed solely for hydraulic purposes.

The department requires the use of the CULVERT software to model culverts within the 12d Model™ application. The reasoning for this requirement is that the software:

- provides records of the culvert design
- produces the drawing of the designed drainage cross-section to departmental standards; that is, showing chainage, skew number, invert heights, culvert component details (including joint type), quantities of precast components and installation materials, and hydraulic design details, and
- incorporates the culvert model into the project electronic model within the 12d Model™ application.

As with all tools, use of this computer program will require output to be checked and verified. It should be noted that this software only helps with the geometric design of the culvert and does not perform any hydraulic calculation. Other software, such as HY-8, Culvert Master and Flowmaster, can be used to perform culvert hydraulic calculations.

### **3.3 Culvert Location**

#### Addition

The geometric tolerances for location / position of culverts and minimum cover requirements will be as specified in the drawings or as per the department's Technical Specification MRTS03 *Drainage Structures, Retaining Structures and Embankment Slope Protections*.

As per MRTS01 *Introduction to Technical Specifications*, the determination of the 'skew angle' and/or 'skew number' for a skewed culvert installation is shown in Figure 3.3. These terms are used to specify the horizontal orientation of skewed culvert structures relative to the road centreline.

The skew number is the number of degrees measured in a clockwise direction from the road centreline to the structure centreline. Skew number is required for ordering metal structures.

**Figure 3.3 – Skew angle / skew number**

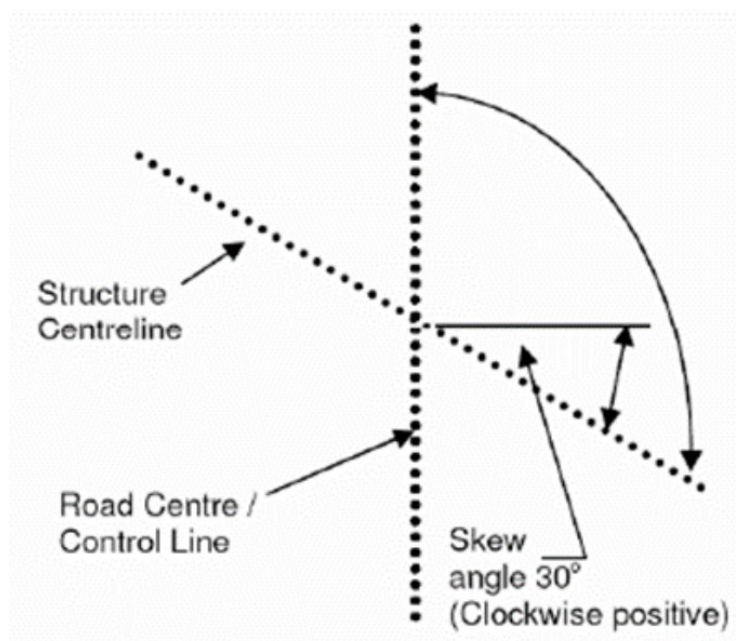

### 3.3.3 Non-hydraulic Considerations

#### Addition

Culverts are considered as a waterway barrier and can limit fish movement along the waterway. Defined waterways require a culvert design that supports fish passage.

Refer to Section 3.3.7 of RPDM Volume 3, Part 5 *Drainage – General and Hydrology Considerations* for culvert specifications for fish passage.

Refer to Section 3.3.8 of RPDM Volume 3, Part 5 *Drainage – General and Hydrology Considerations* for considerations for terrestrial passage.

**Culvert features for fauna passage:** Other features associated with terrestrial passage are discussed below. The value and need for each of these features must be assessed on a site-by-site basis.

**Separate wet and dry cells:** Most culvert designs will have requirements for some degree of terrestrial or aquatic movement. Thus, most multi-cell culverts will require both wet and dry cells.

Separate wet and dry cells can be formed by placing individual cells at different invert levels. This may be achieved by having the two outside cells raised at least 100 mm above normal water level or lowering one central cell below normal water level.

Dry cells can also have a dual use as pedestrian tunnels and bikeways.

**Low flow channel:** In some cases, in order to satisfy both aquatic and terrestrial passage requirements, it may be desirable to construct a low flow channel into the base slab rather than constructing a raised ledge.

**Fencing:** Fencing, such as koala-proof fencing, as shown in Figure 3.3.3, or wildlife exclusion fencing, can be used to direct animals to the culvert to avoid animals moving over the road.

For guidelines on the use and design of fauna control fencing, refer to Volume 1 and Volume 2 of the department's *Fauna Sensitive Road Design Manual*.



**Figure 3.3.3 – Koala fencing**



**Habitat:** As a general rule, the cells of a culvert should not be modified to provide or promote habitat of birds and terrestrial animals. The reason for this is that these habitats are not natural and are likely to be destroyed during flood events.

**Lizard run:** If, for any reason, a dry ledge or dry cell cannot be constructed, then a lizard run may be considered.

Lizard runs are approximately 100 mm wide strips of timber bolted to the waterway embankment side of a culvert cell. They are introduced to a culvert to enable smaller reptiles to move through the culvert at an elevated height.

Lizard runs should be located approximately 300 mm below the obvert of the cell and must extend from ground level at the upstream wingwall, through the culvert to ground level at the downstream wingwall.

**Sidewall roughness:** As an alternative to constructing a lizard run, the culvert cell wall adjacent to the watercourse bank could be roughened with texture paint, grout or other suitable material to allow for the movement of fauna such as lizards.

Any increase in culvert wall roughness must be taken into account in the hydraulic analysis when designing the culvert. However, it is noted that in a typical road culvert, sidewall friction only represents around 12% of the total head loss.

**Street lighting:** Many animals move only at night. To assist in the passage of such animals, street lighting adjacent to culverts should be fitted with metal shields to prevent the lighting of the culvert entry and exit.

In some circumstances, it may be desirable to paint the concrete wingwalls and apron in a dark colour (dark green) to minimise the reflection of light.

**Lighting:** Many terrestrial animals will not enter a dark culvert, so some means of lighting inside the culvert is important. For example, this lighting could be in the form of a break in the median for a major road.

**Vegetation:** The provision of vegetation at the entrance and exit of a culvert is a key determining factor as to whether native fauna will use the culvert.

Bank vegetation should be extended up to the edge of the culvert. This is especially important if a 'lizard run' or 'fauna path' has been installed.



In critical flood control regions, this bank vegetation may need to consist entirely of flexible (non-woody) species that provide minimal hydraulic resistance (that is, no shrubs).

### **Stock underpass**

Stock underpasses (also known as ‘cattle creeps’) are primarily designed for the purpose of allowing cattle to be driven under road formations and, therefore, should remain dry most of the time.

If the culvert is to also be used to convey water under the road during storm events, channels leading to and away from the culvert must have sufficiently flattened side slopes to allow easy passage for cattle. The outlet channel must allow the culvert to completely drain after a storm event.

The culvert must be at least 2.4 m in height to allow a person on horseback to be able to ride through the culvert (they can bend low in the saddle).

For cattle to enter a stock underpass, sufficient daylight from the other side needs to be seen by the cattle, otherwise they will balk and not enter. Suggested number and width of cells is 3 x 2.4 m minimum for culverts up to 15 m in length.

## **3.4 Culvert Type**

### Addition

Selection of the most appropriate type of culvert is dependent on a range of factors, including economics, site conditions and environmental considerations.

Box culverts are generally used where:

- insufficient embankment depth or cover for pipes exists
- channel is narrow and it would be difficult to fit a pipe culvert, and
- fauna passage is required.

### **3.4.1 Culvert Shape**

#### Addition

In multi-cell construction, slab linked box culverts (SLBC) are often an economical choice.

Historically, while the majority of culverts installed consist of concrete pipes or box culverts, the installation of corrugated metal pipes, pipe-arch or arches, may be appropriate and economic in some situations.

Metal culverts have some advantages in lower cost and ease of transport and installation. However, disadvantages, such as corrosion due to construction damage, high compaction standards and higher cover requirements, mean that unless there are large financial savings or other construction restraints, other more robust and more durable materials should be used.

Table 3.4.1 provides guidance in the selection of the most appropriate culvert type for different exposure conditions.

**Table 3.4.1 – Culvert types for different conditions**

Exposure condition	Concrete box culverts (normal cover)	Concrete box culverts (saltwater cover)	Concrete pipes	Steel corrugated arch <sup>1&amp;2</sup>	Steel helical pipe <sup>1&amp;2</sup>	Aluminium helical pipe <sup>2</sup>
Saltwater	x	✓	✓	x	x	x
Aggressive soil (for example, low pH, high chloride, high sulphate)	x	x	x	x	x	✓
Invert in fresh water for prolonged periods	✓	N/A	✓	x	x	Not economic
Typical condition (that is, none of above)	✓	N/A	✓	✓	✓	Not economic

Notes:

<sup>1</sup> Refer Appendix C, AS/NZS 2041 *Buried Corrugated Steel Pipes*

<sup>2</sup> Refer Section 3.6 for structural requirements

Reference should also be made to SD1359 for installation requirements, cover, spacing and details for H2 and HS3 support conditions.

### 3.4.2 Materials

#### Addition

There are three types of joints for reinforced pipes:

- flush or butt joint
- rubber ring joint / spigot and socket, and
- jacking.

Designers should choose the most appropriate joint type for each installation.

Flush or butt joint pipes are best suited where ground movement is not expected. They are an economical option, but installations require a high level of compaction where the resulting soil envelope is extremely stable.

Rubber ring joint / spigot and socket-type pipes allow for ground movement more than flush joint pipes and should generally be used for all sizes of pipe in unstable ground, when pipes are laid in sand, or where pipe movement is possible, such as on the side of fills or at transitions from cut to fill. This type should also be used where the normal groundwater level is above the pipe invert.

Jacking pipes are used where conventional excavation / laying / backfill methods are not feasible. Designers should refer to manufacturer's guidelines for selection, use and design detail for jacking pipes.

### **3.5 Culvert Size**

#### **3.5.1 Minimum Culvert Size Allowable**

##### Difference

The requirement stated in the Austroads *Guide to Road Design – Part 5B* for a minimum 750 mm diameter pipe where there is a risk of debris does not apply.

The minimum diameter of any pipe for highways shall be 375 mm for the longitudinal drainage system and 450mm diameter for the transverse drainage system. Smaller conduits may be considered for lower order roads and driveway accesses.

The minimum waterway dimension (height) of any box section shall be 375 mm; however, in constrained situations and where all reasonable attempts to fit a 375 mm high box section have failed, a minimum 300 mm high box culvert can be used.

#### **3.5.2 Other Sizing Considerations**

##### Addition

For culverts used as walkways and bikeways, the minimum recommended invert level is equal to the level / height of the 20% Annual Exceedance Probability (AEP) flood event. For the minimum recommended cell height and widths, refer to the Department's *Road Planning and Design Manual*.

### **3.6 Structural Requirements**

##### Addition

Culverts are laid in single or multi-cell installations. Culverts are also laid straight and on a constant slope / grade.

For multi-cell installations, each cell or barrel must be of the same size / dimension. There are two exceptions to this requirement:

- where a different cell size is required in a multi-cell installation to accommodate passage (human or fauna), and
- in a SLBC installation where the spanning slab(s) maybe longer than the width of the box unit (refer manufacturer for additional details).

Where a different cell size is required, the designer should note that design software, Standard Drawings and Technical Specifications do not fully cover these types of installations. Therefore, the designer is required to 'manually' design these installations and include all details and specifications in the model / drawings / project documents.

As per the department's Technical Specification MRTS03 *Drainage Structures, Retaining Structures and Embankment Slope Protections*, rubber ring joint / spigot and socket pipes are placed with their spigot end facing the culvert outlet.

### 3.6.1 Design Loads

#### Addition

The following specifies the requirements with respect to the determination of design loadings for buried structures and selection of correct pipe class, based on the department's Technical Specification MRTS25 *Steel Reinforced Precast Concrete Pipes*.

a) Determination of design loads

The methodology to determine the design loads on a culvert is specified in Section 6 of AS/NZS 3725. With reference to Section 6.5.3.3 of AS/NZS 3725, the calculated distribution of working loads shall comply with the requirements as specified in AS 5100.2 *Design loads*. For uniformity, the department has adopted AS 5100.2 to provide the design criteria for loads on all buried structures. The load distribution ratio is to be in accordance with Section 6.12 of AS 5100.2.

It is important to note that, for departmental projects, Table B2 of AS/NZS 3725 is not accepted as it is based on a load distribution ratio which is not in accordance with AS 5100.2. At the time of issue, all known pipe load and class determination software available from various companies and associations do not use the department's accepted load distribution ratio. This software must not be used until a proof of change can be verified by the Structures Section, Engineering and Technology Branch, Transport and Main Roads.

Design loadings need to be determined for SM1600 and HLP400 loads. Table 5.7.2 of MRTS25 *Steel Reinforced Precast Concrete Pipes* shows correct live load pressures (as it is based on AS 5100.2) for W80 wheel load.

b) Determination of pipe class

The design load, as determined above, becomes the proof load for using Table 4.2 of AS 4058 *Precast concrete pipes (pressure and non-pressure)* to determine the required pipe class.

It is important to note that civil designers are restricted to specifying culverts up to, and including, Class 10 pipes. Any situation or requirement to use higher class pipes must be reviewed and approved by the Structures Section, Engineering and Technology Branch, Transport and Main Roads.

c) Support types

The department generally specifies either H2 or HS3 support types – refer AS/NZS 3725, Transport and Main Roads Standard Drawing SD1359. Other support types can be used; however, the use of these types be fully detailed and specified in the project's documents as they are not covered by the department's Technical Specifications and/or Standard Drawings.

### 3.6.2 Existing Culverts

#### Addition

The road network is increasingly subjected to vehicles carrying heavy loads and, therefore, planners and designers must consider the freight task for the road link. Bridges and culverts designed since 2004 are in accordance with AS 5100, which has SM1600 design loads and HLP 400 vehicles. Bridges and culverts designed and constructed prior to 2004 do not have a design loading capability equivalent to current design loads. Of particular concern are pre-2004 culverts that are subject to

critical loading, such as structures that have less than two metres of cover (including pavement layers). These structures may influence the freight task capability of the road link in which they are located and should be considered for replacement if they cannot support the anticipated future loads.

Specifically, pre-cast and cast-in-situ culverts purchased or placed in the road network before 1976 were designed for significantly lighter loads and may also be past their design life (which was typically 50 years). This means that pre-1976 culvert structures on the road network with less than 2 m of cover are likely to be subjected to repetitive and/or peak loadings that exceed the structural capacity of the aged culvert structure. This reduces their service life and greatly increases the risk of structural failure.

While critical loading is less of an issue for all culverts with 2+ m of cover, dead loads can be an issue. These structures should also be inspected and replaced if found deficient.

The following requirement (policy) is not intended as a network management tool or guide, and should only be applied on a project-by-project basis.

For all planning, design and construction projects (excluding non-drainage related routine maintenance and sprayed reseals), it is strongly recommended that no pre-1976 culvert be retained. Retaining any pre-2004 culverts, including pre-1976 culverts, is an action that will potentially extend the service life of the culvert (or parts of it, such as centre units of culvert extensions) beyond its design life and placing the structure at greater risk of failure. Therefore, each pre-2004 structure to be retained must undergo the Structural Assessment / Decision Process as shown in Appendix F. While this process applies to all culvert structures, major culverts (as defined in the department's *Structures Inspection Manual (SIM)*) are currently inspected on a regular basis, with records stored in the department's Bridge Information System (BIS). All other culverts are deemed minor culverts, and inspections should be carried out based on the philosophy within the SIM. Inspectors should take an inventory of the structure based on SIM Appendix C and assess the 'Condition State' of the structure using SIM Appendix D. This will be based on available information and access to structure. Use of CCTV may be of assistance to inspect small culverts.

The process within Appendix F details both the engineering and departmental management components of assessment to determine if it is appropriate and/or justified to retain a culvert structure instead of replacing it. Appendix G is to be used in conjunction with Appendix F and assists the user in determining the risk (probability) of structural failure of a given culvert. Further advice in relation to structural requirements can be obtained from Structures Section, Engineering and Technology Branch, Transport and Main Roads. Advice in relation to inspections can be obtained from Structures Section, Engineering and Technology Branch, Transport and Main Roads.

It is highly recommended to replace steel culverts greater than 15 years of age. Departmental experience has shown that these structures do not generally last much longer than 15 to 20 years and structural failure of these types of culverts can occur quickly.

The requirement for inspection may be relaxed if a pre-2004 culvert is assessed as hydraulically deficient when compared to the project's performance and capability requirements. In this instance, the culvert should be replaced to improve hydraulic capability, and this would remove the requirement for structural inspection. However, if it is intended to retain the existing structure and simply modify it to meet project performance (hydraulic) requirements, the 'inspection / decision to retain' process is required.

### 3.6.3 Space between Pipes in Multiple-Barrel Culverts

#### Addition

When two or more barrels of pipes are laid parallel, they should be separated by the dimensions as shown on the relevant Transport and Main Roads Standard Drawing and within MRTS03 *Drainage Structures, Retaining Structures and Embankment Slope Protections*. The spacing allows for thorough compaction of the backfill material, which is essential for haunch support and the prevention of settlements.

For multiple cell culverts in a restricted natural waterway, box culverts can make better use of the width available, particularly when SLBCs are used.

For large culverts, it is often possible to use link slabs to reduce costs. In these situations, selection of an odd number of box culvert cells is preferred, though by no means essential. An odd number of cells should only be sought if no other design criteria are compromised.

### 3.6.4 Cover

#### Addition

The geometric tolerances for location / position of culverts and minimum cover requirements will be as specified in the drawings or as per the department's Technical Specification MRTS03 *Drainage Structures, Retaining Structures and Embankment Slope Protections*.

### 3.6.5 Structural requirements for new structures

#### New

The design life for all culvert types is 100 years. For further details, including design life criteria for ancillary drainage structure components (for example, culvert headwalls), refer to Section 17 of the department's *Design Criteria for Bridges and Other Structures* manual.

The following departmental Technical Specifications apply to culvert components:

- MRTS03 *Drainage Structures, Retaining Structures and Embankment Slope Protections*
- MRTS24 *Manufacture of Precast Concrete Culverts* – for concrete box culvert components
- MRTS25 *Steel Reinforced Precast Concrete Pipes*, and
- MRTS26 *Manufacture of Fibre Reinforced Concrete Drainage Pipes* – for fibre-reinforced pipe components.

Steel culvert components do not currently have an applicable departmental Technical Specification and do not meet the 100-year design life requirement without protective coatings.

New culvert installations must maintain the same size diameter pipe / box dimensions for its whole length.

For culverts being extended:

- a reduction in culvert size is not permitted on the downstream side as the discontinuity between the different pipe sections can 'catch' debris causing blockage which, in turn, reduces the capacity of the culvert and/or can cause failure of the culvert, and
- a reduction in culvert size is permitted on the upstream side provided that the hydraulic capability is not compromised.

This also applies for projects where the inflow to an existing culvert has been reduced and the culvert requires extension.

Where culverts require strengthening by insertion of a sleeve or similar, the internal dimensions / diameter must be maintained for the length of the culvert.

### **3.6.6 Reinforced concrete pipes**

#### New

The strength classes of reinforced concrete pipes (RCPs) generally used are 2, 3 and 4. The minimum strength class for concrete drainage pipes should be Class 2.

Higher strength pipes, expressed as multiples of 2 (6, 8 and 10), are also manufactured to order.

It is important for designers and construction contractors (essential for the latter) to consider construction loads when determining pipe class during design / installation of culverts to avoid overstressing installed pipe units and cause cracks / fractures. While temporary load mitigating measures during construction exist, it may be an economical solution to use a higher-class pipe.

With reference to AS/NZS 3725 and Transport and Main Roads Standard Drawing SD1359, the support condition normally used is H2 for both embankment and trench installations. The HS3 support condition should be used where the height of the cover is critical and where significant savings can be made by using a lower-class pipe.

To illustrate this point, the H2 support condition is typically cheaper to construct than HS3. However, under the same site, load and cover conditions, it may be possible to use a lower strength pipe, together with HS3 support than compared to a higher strength pipe with H2 support. These combinations of pipe strength and support condition should be cost analysed to determine an economical solution.

The load on a pipe installed in a trench depends upon the width of the trench and is particularly sensitive to any changes in this dimension. Therefore, the trench width specified by design is a maximum allowable and not a minimum.

It is important that the maximum allowable trench widths used in the design be strictly adhered to during construction. If any doubt exists as to whether the design trench width can be maintained (for example, wet weather causing erosion and slips of the trench wall), it is recommended that the embankment installation be used to determine allowable heights of embankment.

For heights of cover less than 3 m, the allowable height depends on both live and earth loads. At these lower heights, the live load is a major contributor to the total load on the pipe.

Design engineers can use other support conditions as detailed in AS/NZS 3725; however, Transport and Main Roads Standard Drawings and Technical Specifications do not address these.

### **3.6.7 Fibre-reinforced concrete pipes**

#### New

Table B1 information on fibre-reinforced concrete pipes (FRCPs) in Appendix B of Austroads *Guide to Road Design – Part 5* is accepted for this section with below amendments.

They are generally suitable anywhere an RCP could be used. The reinforcement is a cellulose (wood fibre) product. Hydraulic design curves for precast RCPs are appropriate, although FRCPs have slightly lower roughness coefficients.

### 3.6.8 Reinforced concrete box culverts

#### New

Appendix B, Table B.1 of Austroads *Guide to Road Design – Part 5* is accepted for this section subject to below amendments.

In accordance with the department's Technical Specification, MRTS24 *Manufacture of Precast Concrete Culverts*, standard reinforced concrete box culvert (RCBC) and link slab components have been manufactured to withstand a maximum height of fill (including pavement) of 2.0 m. For higher fills (including pavement), a special design for proposed installation is necessary.

For multi-cell installations, SLBC construction should be considered, as shown in Figure 3.6.8. Details are shown on SD1250 and SD1260.

RCBC and SLBC construction can be used with nominal minimal cover above the culverts. Nominal cover has advantages in regions where the height of the overall formation is critical.

In expansive soil areas, RCBC and SLBC installations require special consideration.

Where baffles for passage are designed, installation of ferrules for bolt in points can be requested in the pre-cast or cast-in-situ box culverts. This should be done to avoid construction constraints of drilling anchor points into reinforced concrete box culverts and potentially reducing concrete cover on reinforcing steel.

**Figure 3.6.8 – Slab link box culvert under construction**



### 3.6.9 Reinforced concrete slab deck culverts

#### New

The standard reinforced concrete slab deck culverts of 2500 mm span allow for a maximum fill of 2500 mm above the slab deck and is a cast-in-situ structure (refer Transport and Main Roads Standard Drawing SD1240).

### 3.6.10 Corrugated steel pipes

#### New

Corrugated steel pipes, as shown in Figure 3.6.10(a), offer a lightweight alternative when compared to concrete pipes. The use of such pipes is not generally favoured due to the reduced life spans they have exhibited to date in the field. However, they may be considered if the design life requirement is



purposely relaxed to suit the constraints of a particular situation. An example of this is when transport of alternative materials over long distances becomes excessively costly. In making such a choice, the shorter expected life span must be recognised, and replacement of the structure appropriately programmed.

**Figure 3.6.10(a) – Corrugated steel pipes**



Source: Catchments and Creeks Pty Ltd

The following Australian Standards are relevant to corrugated steel pipes:

- AS 2041.1 – *Buried corrugated metal structures – Design methods*
- AS 2041.2 – *Buried corrugated metal structures – Installation*
- AS 2041.4 – *Buried corrugated metal structures – Helically formed sinusoidal pipes*
- AS 2041.6 – *Buried corrugated metal structures – Bolted plate structures*

The department's Technical Specification, MRTS03 *Drainage Structures, Retaining Structures and Embankment Slope Protections*, also contains requirements for supply and construction of metal culverts.

New steel culvert components must have a protective coating applied to both internal and external surfaces in order to meet the required 100-year design life. The protective coatings must conform to:

- galvanising to Z600 in accordance with AS 1397, and
- a polymer coating to ASTM A742.

Before specifying in design / used in construction, any proposed steel culvert product with this protective coating applied must be approved by the Structures Section, Engineering and Technology Branch, Transport and Main Roads.

Additional design requirements for helical culverts are:

- the maximum diameter of helical pipe culverts complying with AS 2041 shall be 3600 mm, and
- the maximum flexibility factor for installation shall not exceed the limits in AS 2041.

Apart from this protective coating requirement, steel culverts must also have invert protection. The invert of all corrugated steel pipe culverts shall be lined with concrete as follows:

- Concrete Class: 32 MPA / 9.5
- minimum depth of concrete above corrugations: 50 mm, and
- minimum height of lining above invert to be  $D/6$ , where 'D' denotes diameter as shown in Figure 3.6.10(b).

**Figure 3.6.10(b) – Culvert lining details**

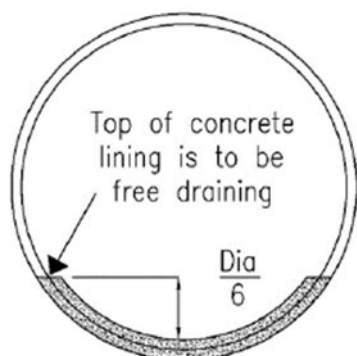

It is important to note that any bolts or lugs that are connected to the culvert to allow anchorage for the concrete invert must also be covered by the protective galvanising / polymer coating.

Further details for concrete lining are contained in the department's Technical Specification MRTS03 *Drainage Structures, Retaining Structures and Embankment Slope Protections*.

The design of corrugated metal helical pipe and arch culverts is not as simple as for concrete culverts and should be undertaken by an experienced design engineer. Furthermore, installation of metal culverts is also specialised and should be undertaken by qualified / experienced personnel. Assistance and advice with respect to the design and installation of metal culverts can be provided by the Structures Section, Engineering and Technology Branch, Transport and Main Roads, when required.

### **3.6.11 Plastic flexible pipes**

#### New

Polyethylene and polypropylene pipes are available but are not currently approved for use as culverts under a state-controlled road (refer to the department's Technical Note 103 *Vandalism of Plastic Pipe under Roads, Rail and Similar Infrastructure* available on the departmental website). They can be considered for applications which are not subjected to traffic loading. In these instances, confirmation of acceptance for the proposed use of these culvert types should be sought from the department.

### **3.6.12 Aluminium culverts**

#### New

Appendix B, Table B.1 of Austroads *Guide to Road Design – Part 5* is accepted for this section.

### 3.6.13 Splay pipes

#### New

The use of splay pipe components to construct 'bends' in culverts is not permitted. However, a relaxation of this requirement may be approved for individual cases within a project subject to the following requirements:

- specific locations where it is proposed to use splay pipes to construct bends in culverts are to be reviewed and approved by the department's design representative
- culverts must conform to relevant departmental Technical Specifications
- bends are to be constructed in large culverts only – for pipe diameter of 1200 mm or greater using proprietary splay pipe units, and for box culverts with widths and heights of 1200 mm or greater using a cast-in-situ chamber without access
- bend angles are restricted to a total or maximum 22.5° culvert deflection in the horizontal plane only (grade of culvert must not change)
- only one bend is allowed in a single culvert installation, and
- the detailed design of any culvert that includes a bend will require formal approval by Structures Section, Engineering and Technology Branch, Transport and Main Roads.

### 3.6.14 Other structural aspects

#### New

All other structural aspects should be referred to the Structures Section, Engineering and Technology Branch, Transport and Main Roads, for advice and/or guidance.

## 3.7 Hydraulic Design Considerations

### 3.7.2 Outlet Velocity

#### Addition

The calculation of outlet velocity is required for every culvert, and the type and extent of protection should be decided after consideration of the outlet velocity, the natural downstream ground conditions, the natural stream velocities, and the performance of existing culverts in the area.

### 3.7.4 Siltation and Blockage

#### Addition

Book 6 of ARR is accepted for this section.

### 3.7.6 Tailwater (TW)

#### Addition

Section 2.6 of the Austroads *Guide to Road Design – Part 5B* is accepted for this section, in addition to below amendments.

Tailwater is important for drainage design as it sets the water level at the outlet of a drainage structure. It, therefore, can control the hydraulic performance of the structure.

Tailwater levels must be calculated as part of the hydraulic design for all drainage structures. There are a number of situations required for the calculation of tailwater, as follows:

- Normal stream depth – in this case, the tailwater level is defined by the normal water level in the downstream channel dependent on the conditions of the stream or creek. These conditions are the slope, channel geometry and stream roughness. The tailwater level is calculated using Manning's Equation, backwater analysis or a stream rating curve.
- If there is a downstream confluence (junction) with another stream, the tailwater level may be held at a higher level than would naturally be the case. In this case, the flow is at a lower velocity and the water levels are higher, which means that the culvert will not operate as efficiently as it would if the downstream water level was lower. This is especially the situation if the road crosses a tributary just before this tributary joins a major stream. Two cases need to be analysed. First, assuming a major flood in the downstream catchment of the major stream, this may result in a higher flood level in the tributary, which may be critical for the design. Second, assuming normal to low flows in major stream, a local catchment flood in tributary may result in lower flood levels but make a critical case for the consideration of velocities through the structure.
- Similar to the tributary situation, a downstream lake or dam can affect the tailwater level. In this case, the stream flows into a lake, natural or artificial, and this body of water holds up the flood levels and thereby increases the tailwater level. This increase can occur over time, giving a dynamic tailwater.
- Another infrastructure crossing or artificial constriction downstream of proposed crossing can affect tailwater levels.
- If the road crossing is close to the ocean or an estuary, the tailwater level may be controlled by the level of the ocean. In this case, the water level will depend on tidal levels, as well as possible effects from storm tides or waves. The assessment of an appropriate tidal tailwater level for design of drainage structures is a difficult problem. A major issue is the risk of occurrence of a particular tide at the same time as a major flood. Analysis of a range of tidal levels may be of value as for the consideration of a downstream tributary. If a high tide is analysed, this may give the critical event for flood levels on the road, but the flow velocities will be low. On the other hand, analysis of a lower tide will give lower flood levels, but the flow velocities may be critical for the design.

### **3.9 Hydraulic Calculations**

#### Addition

Culverts designed for hydraulic purposes only are designed to pass the design discharge from one side of the road embankment to the other in a cost-effective manner in accordance with individual project requirements.

The velocity of the water through the culvert is usually greater than the approach velocity in the stream because the culvert presents a smaller cross-sectional area of flow than the stream.

As detailed in the previous chapter, the energy in water is measured as head (m). When water flows through a culvert, several losses of energy occur:

- Firstly, as the flow accelerates into the culvert (known as entrance loss).
- Secondly, there is friction loss along the length of the barrel as water flows against the culvert, and
- Finally, as the flow decelerates out of the culvert (known as exit loss).

In order to pass the design discharge through the culvert, extra energy within the flow is required on the upstream side to overcome these losses. This extra energy is generated by 'damming' the flow on the upstream side of culvert / road formation which raises the water level (increases the height of water or head) above that of normal flow levels. This increase in level is known as afflux, and it is at its highest just upstream of the culvert entrance.

The overall increase in water depth (afflux) generated by the culvert cannot exceed the allowable headwater for the site.

Reduction of the culvert outlet discharge velocity is normally achieved by increasing the waterway area of the culvert; however, this is not always possible and outlet protection, as shown in Figure 3.9, may have to be designed.

**Figure 3.9 – Box Culverts with riprap**



Source: Catchments and Creeks Pty Ltd

### **3.10 Design Procedures**

#### **Addition**

This section describes an approach or general process for the design of culverts. Some of the work described in the following sections may not be required for each design of a culvert.

The design of a culvert commences with assembling the data related to the drainage site, including detailed survey of the site, site inspection data and other site-specific information, including environmental and geotechnical reports.

A generalised approach to the design of the culvert follows:

a) Collate site data

Review survey, topographic information, locality map, photographs, aerial photographs and details from field visit to determine/understand:

- Catchment / waterway details, including natural constrictions, bends, low / high flow channel, vegetation, potential overflow to other crossings, and so on
- upstream and downstream conditions and details
- location of any geotechnical issues
- location of environmental constraints or identification of environmental issues
- location of Private / Public Utility Plant (PUP) or other physical constraints
- any stream or channel diversion issues
- any culvert skew requirements
- soils data
- existing and allowable stream flow details (depth, velocity, energy and so on)
- any possible / identified inlet and outlet erosion issues, and
- possible sediment / debris issues.

It is also essential to review:

- recorded and observed flood data, and local anecdotal data from residents or local council
- design data for nearby structures, and
- studies by other authorities near the site, including small dams, canals, weirs, floodplains and storm drains.

From this information, the designer can then commence the design to determine the size and alignment of the culvert.

b) Determine road / channel geometry

Where the road alignment crosses the stream / channel, the designer needs to determine / understand:

- the grade height of the road over the crossing
- location of adjacent low points in the road alignment
- height and width (location) of shoulders (both sides) considering crossfall / superelevation application
- embankment or batter slopes (and possibility of steepening the slopes if height of embankment over culvert is too high)
- pavement thickness

- shape of channel (width of bed and bank slopes), including uniformity of shape over the reach where the culvert will be located, and
- channel bed slope.

These parameters are required to determine the maximum height, width and minimum length of the culvert. This allows the designer to 'fit' the culvert under road and within the channel. The parameters also allow the determination of the height of headwater that can be developed upstream of the culvert.

c) Determine culvert type and location

Select a suitable culvert type (RCP, RCBC and so on) for site and locate the proposed culvert along the best initial alignment and determine the following:

- an initial trial culvert size and configuration that 'fits' (refer 'b')) and check cover requirements for selected culvert type
- incorporate any environmental requirement, such as fauna passage
- set an outlet invert level
- based on the channel bed slope and an initial slope for the culvert, determine the inlet invert level
- check that the inlet invert level is at or just below the natural bed level
- if the inlet level is well below the natural bed level, assess the extent of inlet works needed to avoid / minimise siltation over time
- check / determine available space for possible ancillary erosion or environmental protection devices, and
- identify and document any possible issues / limitations that may necessitate a review of the culvert design or its location.

d) Determine tailwater level

- Calculate the tailwater level within the existing channel immediately downstream of culvert outlet.

e) Undertake hydraulic design

- determine / set the maximum allowable headwater, including freeboard, for the design
- complete the hydraulic design of proposed culvert to determine headwater, control, outlet velocity Froude number, and
- undertake several trials based around the initial culvert size / configuration, including cost comparison, to select optimum design.

f) Review hydraulic design output

- check if hydraulic design is reasonable / realistic and if the flood immunity requirements are being achieved
- check generated headwater against maximum allowable headwater
- check outlet velocity against permissible channel velocities

- check extent of any additional inundation due to afflux and review impacts to adjacent property, and
  - assess the likelihood of road overtopping or excessive / erosive outlet velocities in an extreme rainfall event (how close is generated headwater to shoulder point / outlet velocity to maximum permissible).
- g) Check connections
- Can surface drains, such as catch drains and diversion drains, be drained to the culvert inlet and/or outlet?
  - Can underground drainage be drained to the culvert inlet and/or outlet?
- h) Assess mitigation treatments
- Determine any inlet or outlet protection devices to address pollution or erosion control concerns.

As the designer works through this step-by-step process, there will be some outcomes that indicate revisions to the proposed culvert need to be made. The designer needs make amendments to the proposal and restart the geometric design at an appropriate point and continue the design with the amended culvert proposal.

When designing culverts, construction and future maintenance requirements must be considered with appropriate treatments incorporated into the design. Some guidance with respect to construction requirements and methods can be found within various departmental Standard Drawings and Technical Specifications. However, this must not prevent all hydraulic and environmental requirements from being satisfied.

Relevant Transport and Main Roads Standard Drawings for culverts are: SD1240, SD1241, SD1243, SD1250, SD1260, SD1304, SD1305 and SD1359.

Additional Transport and Main Roads Standard Drawings related to fish passage are SD1270 and SD1271.

The main departmental Technical Specifications are MRTS03 *Drainage Structures, Retaining Structures and Embankment Slope Protections* and MRTS04 *General Earthworks*.

For any possible non-standard or complicated culvert configurations, it is highly recommended that designers should involve construction personnel early in the design process to provide site-specific construction / constructability advice.

### **3.11 Blockage of Culverts**

#### Addition

Book 6 of ARR is accepted for this section.



### **3.13 Culvert Outlet Protection**

Sections 3.13 and 3.14 of Austroads *Guide to Road Design – Part 5B* is accepted for this section subject to amendments.

#### Addition

In all types of culvert outlets, protection of the stream bed would normally be provided by the department's standard apron treatment as per SD1240, SD1250 and SD1260. Typically, the distance of protection required, measured from the outlet of the culvert, is  $1.5D$  metres where 'D' is the diameter of a pipe or the height of a box culvert.

Wingwalls, in conjunction with the apron and cut-off wall, protect the integrity of the embankment from erosion / scour caused by stormwater flows.

The length of the wingwall (W1 & W2 as per SD1240, SD1250, SD1260, SD1304, and SD1305) is calculated based on the slope of the batter – the flatter the batter slope, the longer the wingwall needs to be. The wings should extend to at least the interface between the batter slope and the natural slope. For further detail on calculating wingwall lengths, refer to Appendix H.

Should shorter wingwalls be proposed (that is, some of the embankment is exposed to inlet / outlet flow), it is recommended that there be a requirement to mitigate any possible erosion / scour of the exposed embankment via works with a similar durability / design life as normal wingwalls (typically 50 years).

Use of pre-cast end / headwalls must comply with the department's Standard Drawing SD1243 and Technical Note TN27 *Guidelines for Design of Precast Culvert and Pipe Headwalls*. NB: For concrete pipe culverts there is to be no step between the culvert invert level and the adjacent apron level. This requires the depth of the recess in the precast end unit to match the thickness of the concrete pipe.

#### **3.13.1 Flap Gates (Tides and Floods)**

##### New

Where the outlet to a culvert may be submerged by tide or a flood from downstream sources, and where it is necessary to prevent the flow of such waters into the culvert, it may be necessary to install flap gates. However, flap gates will generally cause a higher head loss to occur. Therefore, reference should be made to loss coefficients as provided by the manufacturers.

Where flap gates are required, it will be necessary to ensure that only those culvert types for which gates are available are selected. Obvious impacts on fish passage must also be considered.

Regular maintenance of flap gates is required to ensure their efficient operation. This is especially important for locations where there is significant debris or sediment transport. If regular maintenance is unlikely, then flap gates may not be appropriate.

In addition, if the culvert is expected to pass large quantities of sand, then the outlet should be raised above the downstream invert to avoid sediment blockage of the gate(s).

### **3.14 Culvert End Treatments**

#### Addition

Accepted as per Section 3.13 of this supplement.

### 3.14.1 General

#### Addition

Accepted as per Section 3.13 of this supplement.

### 3.14.2 Slope Faced

#### Addition

Accepted as per Section 3.13 of this supplement.

### 3.14.3 Traversable Endwalls

#### Addition

Accepted as per Section 3.13 of this supplement.

## 3.16 Culverts in Expansive Soil Areas

#### New

Expansive soils pose particular problems in civil engineering works due to shrink-swell behaviour. With respect to drainage structures, this movement in the soil places uneven stresses on RCBCs, SLBCs and reinforced concrete culverts (RCCs), and can damage the structure as shown in Figures 3.16(a) and 3.16(b). In Figure 3.16(a), the longitudinal crack stops at the slab which forms the footing of the wingwall. While the apron has risen relative to the wingwall, the outer edge of the apron has dropped and now slopes away from the culvert. Figure 3.16(b) shows the vertical displacement across the break in the apron slab. Again, the apron has risen relative to the wingwalls.

**Figure 3.16(a) – Longitudinal cracking of apron failure**

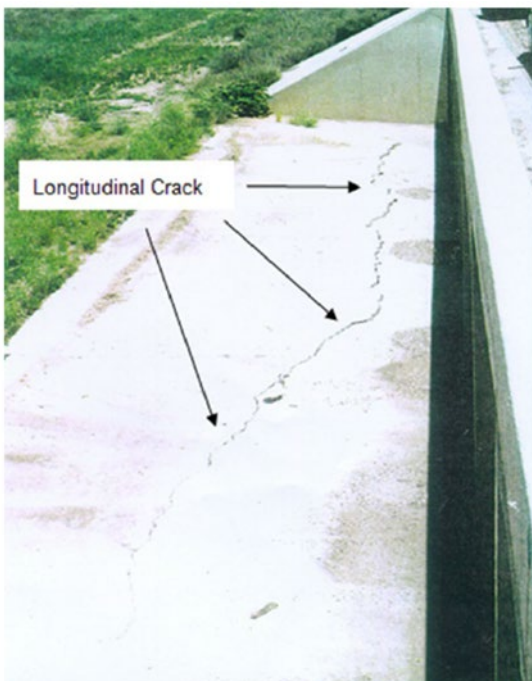

**Figure 3.16(b) – Vertical displacement of apron failure**



Other issues, such as culverts which appear to rise above their original level, approaches to culverts that deform and pavement distress over culverts, are often the result of volume changes in expansive soil foundations and embankments. With differential ground movements taking place at the culvert / approach interfaces, heavy vehicles can inflict high axle impact loads on the structure. The design load of culverts is influenced more by high impact loads of individual axles, rather than the behaviour of the entire vehicle. High impacts on structures can dramatically reduce service lives.

This section addresses:

- multiple barrels, RCBCs and SLBCs, and
- multiple barrels, RCCs with a total length greater than 10 m along the road centreline in expansive soil conditions.

### **3.16.1 Expansive Soil Potential**

#### New

The shrink-swell behaviour of expansive soils is caused by moisture movement in the soil brought about by climatic changes producing moisture variations from extreme wet to extreme dry or vice versa. Examples are:

- soils in arid climates, usually in a desiccated state (cracked), which are subjected to occasional unusually high rainfall or prolonged inundation, causing the soil to saturate and expand
- soils in semi-arid climates where the moisture conditions of the soil reflect the wet-dry seasonal cycle and may be subjected to occasional climate extremes of drought and flood, and
- predominantly wet soils which, from time to time, are subjected to a prolonged period of drought and exhibit drying shrinkage.

The shrink-swell behaviour or volume change phenomena is controlled by three major factors:

- intrinsic expansiveness of the soil (generally characterised by shrink-swell index for the soil)
- suction change (site-specific and dependent on the atmospheric conditions), and
- applied stress.

Changes in soil moisture produce suction changes which, in turn, produce a loading / unloading effect on the soils and result in volume changes in the soil. The two most important site-specific issues with regard to suction are:

- the postulated suction change at the surface, and
- the depth over which the suction change manifests, known as the active depth (generally between 2–5 m).

While some guidance is available for expansive soil embankments in road construction, the problem with drainage structures in expansive soils is different in that it is a soil / structure interaction condition.

Experience has shown that expansive soil problems generally tend to occur in soils which have a Linear Shrinkage greater than 8% and/or swell strains greater than 5% at optimum moisture content (OMC) (based on a multi-point soaked California bearing ratio (CBR) test).

According to the Unified Soil Classification, these soils range from SC/CL to CH and are not necessarily restricted to high plasticity CH clays.

Therefore, particular design and/or construction considerations need to be adopted to avert damage to culverts where expansive soils are exposed to significant long-term moisture changes.

### **3.16.2 Postulated Mechanism of Distress**

#### New

The observed movement in some large culverts is generally a movement of the outer edges of the culvert relative to the central section of the culvert, which is generally immune to the movement.

Figure 3.16.3 depicts this failure mechanism for two case study sites.

It is considered most likely that the outer edges, being the apron slabs, are subjected to extremes of wetting / drying phenomena, which produce either high swelling pressures or lack of base support.

Most small culverts (< 10 m along the road centreline) generally only suffer small movement, which is satisfactory, or exhibit a uniform heave due to their inherent geometric stiffness.

### **3.16.3 Standard Drawings**

#### New

The current standard drawings for culvert bases do not state the design assumptions on which the drawings are based and, most importantly, situations when the drawings are inappropriate for use.

**Figure 3.16.3 – Failure mechanism of base slabs in expansive soils**

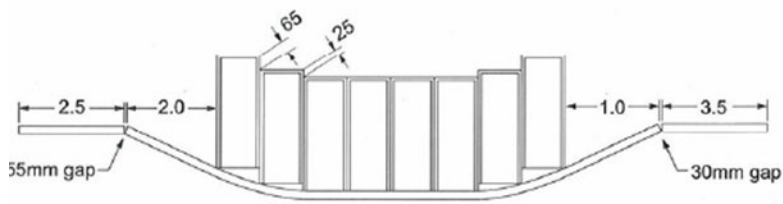

**Failure at Jessamine Creek**

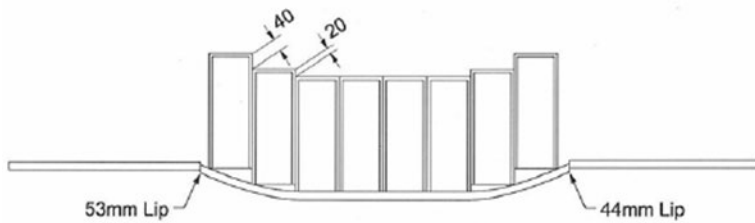

**Failure at Douglas Ponds**

The design assumptions on which the above drawings are based include:

- The base slabs are designed as a beam on a moisture insensitive, elastic foundation; that is, differential settlement due to moisture changes are not a design consideration in the standard drawing.

Sites subject to large settlements or large differential settlements, arising out of moderate or highly expansive soils below the culvert base, are outside the design method of these standard drawings.

### **3.16.4 Amended Design Procedure**

#### New

For culverts with a base greater than 10 m along road centreline, specialist geotechnical and structural advice (from the department's Engineering and Technology Branch) should be obtained where highly reactive or expansive clay soils (linear shrinkage > 8% and/or CBR swell > 5%) occur below the culvert bases. This is to determine if non-standard base slabs or other foundation treatments are required.

### **3.16.5 Foundation Investigation**

#### New

An appropriate, special investigation for culvert bases on expansive soils should be undertaken in a similar manner to the proven need for special bridge site investigations. This work should be undertaken under the direction of specialist geotechnical engineers and/or geologists as appropriate. This is required only if preliminary testing indicates the subgrade to be expansive (that is, LS > 8% and/or CBR swell > 5%). This preliminary testing can be undertaken at the regional level.

It is imperative that a vertical profile is established to determine the extent of the actual expansive zone. A field investigation should include:

- trenching or drilling to 2 m depth under or in the vicinity of the proposed culvert location
- insitu moisture content testing (Q102A) and density testing (Q111A) at every 300 mm in depth or at change of soil horizon, whichever is earlier, to determine the active zone (below the active zone, no significant moisture content changes occur over time). Due to lack of data, AS 2870 gives little guidance on active depths for Queensland conditions. For most other states, such as Victoria, where the reactivity of clay profiles has been the subject of extensive research, useful guidance is available
- 50 mm undisturbed tubes taken from each soil horizon, for shrink-swell index testing and filter paper suction measurements, and
- adequate materials to be sourced from each location for the following laboratory tests.

A laboratory investigation is required for each soil horizon. The required tests are detailed in Table 3.16.5.

If instrumented sites are established in different soil / climatic regions, enabling a rational classification of soil / climatic behaviour response patterns, the level of testing can be reduced in the future.

**Table 3.16.5 – Required tests**

<b>Parameter</b>	<b>Test Method</b>
Particle size distribution (sieve analysis)	Q103A
Liquid Limit	Q104A
Plastic Limit	Q105
Linear Shrinkage	Q106
Shrink-swell index	AS 2870
Filter paper suction measurement	BRE-IP 4/93

### 3.16.6 Options for the Control of Distress in Culverts

#### New

For drainage structures using culvert bases, special measures need to be undertaken to avert distress. Options for control of distress of culvert bases may be categorised into either geotechnical alternatives or structural alternatives. In many cases, geotechnical methods may be used successfully in conjunction with structural methods.

#### a) Geotechnical methods

There are broadly two geotechnical methods for limiting damage to light structures, such as culverts constructed on expansive soil foundations. These either reduce the expansive potential of the soil or minimise the seasonal fluctuations of the subgrade moisture.

#### **Reducing expansive potential of the foundation – volume stability**

Methods for reducing the expansive potential of the foundation may include one of the following:

- excavation of the foundation and replacement with a low permeability granular or non-swelling material
- chemically treating the natural material (for example, lime stabilisation), and
- ripping, scarifying and compacting the soil with moisture and/or density control.

These processes are carried out to a depth beyond the level of seasonal moisture variation within the soil. The areas to be treated would be under the aprons and 1 m beyond the cut-off wall of the apron.

#### **Control of foundation moisture fluctuations – moisture stability**

The aim of these methods is to control the moisture fluctuations in the foundation within acceptable limits. Methods of control may include one of the following:

- pre-wetting or ponding a foundation prior to construction.
- stabilisation of foundation moisture conditions by a physical limit, such as vertical moisture barriers. This involves the placement of a geomembrane (generally a waterproof fabric) in a trench along the perimeter of the slab to the limit of the estimated active zone depth. These vertical barriers minimise seasonal lateral migration of moisture to and from the foundation soils beneath the foundation slab. Details of backfilling and other technical issues will need to be covered by supplementary specifications, and
- extending the concrete apron with a flexible apron, such as grout-filled erosion mattress ( $\approx 3$  m wide) underlain by an impermeable membrane (horizontal moisture barrier). This is aimed at shifting the moisture fluctuation zone to be under the extended apron, thus shielding the concrete apron slab from the edge effects.

Prediction of moisture infiltration under sealed areas by numerical methods may be used in estimating the required lateral extent that needs to be provided by the flexible apron.

b) Structural methods

The structural options to control distress of culvert bases are as follows:

**Improved layout of culverts**

The risk of damage to culvert bases may in some circumstances be reduced by limiting the size of banks of culverts. In wide floodplains, it is considered that a number of banks of culverts distributed across the watercourse will result in a better hydraulic and structural solution.

**Other structural solutions**

The use of stiffened raft foundations (AS 2870) are technically proven solutions widely used in the building industry. As the culvert distress is commonly observed within the apron area of the slab, any stiffening needs only be confined to the apron slab. Swell pressures can be as much as 200 kPa; that is, much greater than the applied pressure at the base of the slab (typically up to 50 kPa). Each case has to be considered on its own merit.

**Other options – bridges**

Consideration should be given to using short span bridges founded on freestanding piles extending to the stable material below the active zone. Due to the limited nature of contact between the volumetrically active soil and the foundation elements, being the free-standing piles, limited upward thrusts are transmitted to the deck. Therefore, these foundation systems are less influenced by the movement of the ground and allow such designs to be optimised. However, expansive soil issues with bridge abutments and general bridge maintenance requirements would still need to be resolved.

Bridges would not be a practical option for low height structures, but the actual height limit has not currently been determined, and it may vary for different sites.

**Improved construction practice**

Consideration should be given to restricting construction practices which adversely affect the moisture content of the soil. The following practices should be excluded:

- placement of permeable fill behind the culvert (either granular or cement stabilised sand)
- opening a culvert base up for a prolonged period when the moisture content is low, and
- not allowing adequate time for the culvert base to reduce moisture content after a prolonged wet period.

Technical Specifications may be required in such situations and may require specialist input from geotechnical and structural specialists within the department's Engineering and Technology Branch.

## **4 Floodway Crossings**

### **4.1 Introduction**

#### Addition

Floodway crossings are sections of roads which have been designed to be overtopped by floodwater. An example of a floodway crossing is shown in Figure 4.1.



**Figure 4.1 – Little Annan River floodway crossing**



These overtopping floods usually have a 5% AEP or higher (Average Recurrence Interval (ARI) 20 years or lower), but any crossing can be designed as a floodway crossing. The Queensland *Manual of Uniform Traffic Control Devices* (MUTCD) describes floodway crossings as sections of road over which water may flow for short periods in times of flood, but the road remains trafficable with care.

## **4.2 Design Considerations**

### **4.2.1 General**

#### Addition

Floodway crossings may offer environmental advantages over culverts or bridges, since they will tend to spread flows more widely. This means that the risk of scour to waterway and surrounding land is generally reduced because flow is less concentrated.

### **4.2.2 Culvert Dimensions and Design Considerations for Culverts Under the Floodway Crossing**

#### Addition

Recent research shows that modern passenger vehicles become buoyant and susceptible to flood forces at much lower levels of roadway inundation than those used to describe closure criteria in previous publications of this manual (300 mm of total head). Additionally, the public safety campaign stating “If it’s flooded, forget it” has been widely publicised and adopted as policy by the department. The closure criterium of 300 mm total head of water is therefore under review and needs to be confirmed on a project-by-project basis until further guidance is available.

Exceptions to the level grading in Queensland occur where bridges have been built significantly higher than the flooded approaches on both sides. The bridges have been built on the basis that the approaches will be raised sometime in the future.

For further geometric requirements of width, crossfall, vertical and horizontal alignment, refer to the relevant chapters of the department’s RPDM Volume 3, Part 3 *Geometric Design*. Signage of the

floodway is also important, and designers are referred to the latest release of the Queensland MUTCD for warrants / guidance.

### **4.3 Hydraulic Design**

#### **Addition**

Nowadays, floodway crossings are more commonly designed using two-dimensional (2D) models, as they better represent overbank, multidirectional or skewed flows, however first principle equations are still relevant and should be used to check modelling results.

### **4.4 Time of Submergence and Closure**

#### **4.4.1 Introduction**

#### **Addition**

Due to the uncertainty about the appropriate closure criterion, for the purposes of departmental projects, the focus of calculations should be on Time of Submergence (TOS) and Average Annual Time of Submergence (AATOS) analysis.

The actual time of closure of a road typically includes a post-submergence clean up and inspection time. If these aspects are important, an estimate of these should be made and added to the TOS.

#### **4.4.3 Time Required to Reopen the Road after Flood Closures**

#### **Addition**

Some roads become inundated for months at a time during the wet season and/or may be inundated by tides. Calculations of TOS for these cases is very difficult and should use either a stream gauge or continuous simulation techniques.

Average time of submergence or closure may be assessed for a range of selected grade levels and a plot of average time of submergence against level may be produced, as in Figure 4.4.3.

**Figure 4.4.3 – Typical deck level / time of submergence relationship**

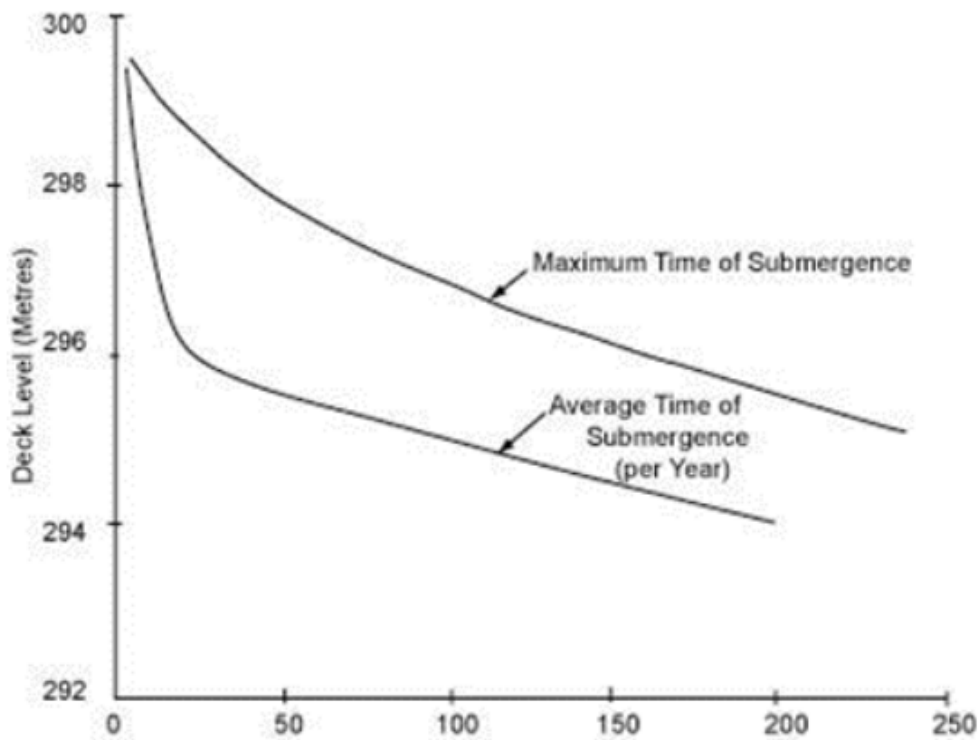

In many cases, the plot will reveal a particular grade level above which a relatively large increase in level will result in only a small decrease in time of submergence, and a small reduction in level results in a large increase in average time of submergence. Such a level may be selected as a starting point for economic analysis.

## References

Department of Transport and Main Roads publication references refer to the latest published document on the departmental website ([www.tmr.qld.gov.au](http://www.tmr.qld.gov.au)).

### Addition

American Society for Testing and Materials. ASTM A742. *Standard Specification for Steel Sheet, Metallic Coated and Polymer Precoated for Corrugated Steel Pipe*

Australian Standard AS 1397. (2011). *Continuous hot-dip metallic coated steel sheet and strip - Coatings of zinc and zinc alloyed with aluminium and magnesium*. Australia: Standards Australia

Australian Standard AS 2041. (1998). *Buried corrugated metal structures*. Australia: Standards Australia

Australian Standard AS 2870. (2011). *Residential slabs and footings*. Australia: Standards Australia

Australian Standard AS/NZS 3725. *Design for installation of buried concrete pipes*. Australia: Standards Australia

Australian Standard AS 4058. (2007). *Precast concrete pipes (pressure and non-pressure)*. Australia: Standards Australia

Australian Standard AS 5100.1. (2017). *Bridge design, Part 1: Scope and general principles*. Australia: Standards Australia

Australian Standard AS 5100.2. (2017). *Bridge design loads*. Australia: Standards Australia

Ball, J., Babister, M., Nathan, R., Weeks, W., Weinmann, E., Retallick, M., and Testoni, I. (Editors). (2019). *Australian Rainfall and Runoff: A Guide to Flood Estimation*. Canberra: Commonwealth of Australia (Geoscience Australia)

Chow, V. T. (1959). *Open Channel Hydraulics*. New York: McGraw-Hill Book Company Inc.

Department of Transport and Main Roads. *Fauna Sensitive Road Design Manual Volume 2*. Brisbane

Department of Transport and Main Roads. *Hydrologic and Hydraulic Modelling Guidelines*. Brisbane: Queensland Government

Department of Transport and Main Roads. *Queensland Manual of Uniform Traffic Control Devices (MUTCD)*. Brisbane: Queensland Government

Department of Transport and Main Roads. Technical Specification MRTS01 *Introduction to Technical Specifications*. Brisbane: Queensland Government

Department of Transport and Main Roads. Technical Specification MRTS03 *Drainage Structures, Retaining Structures and Embankment Slope Protections*. Brisbane: Queensland Government

Department of Transport and Main Roads. Technical Specification MRTS04 *General Earthworks*. Brisbane: Queensland Government

Department of Transport and Main Roads. Technical Specification MRTS24 *Manufacture of Precast Concrete Culverts*. Brisbane: Queensland Government

Department of Transport and Main Roads. Technical Specification MRTS25 *Steel Reinforced Precast Concrete Pipes*. Brisbane: Queensland Government

Department of Transport and Main Roads. Technical Specification MRTS26 *Manufacture of Fibre Reinforced Concrete Drainage Pipes*. Brisbane: Queensland Government

Institute of Public Works Engineering Australasia (IPWEAQ). (2017). *Queensland Urban Drainage Manual* (QUDM), 4th Edition 2016

Witheridge, Grant. (Catchment & Creeks Pty Ltd) & Brisbane City Council (BCC). (2003). *Natural Channel Design Guidelines*. Brisbane: Brisbane City Council

Appendix F – Structural Assessment / Decision Process

New

Figure F-1 – Pre-2004 culvert – structural assessment / decision process

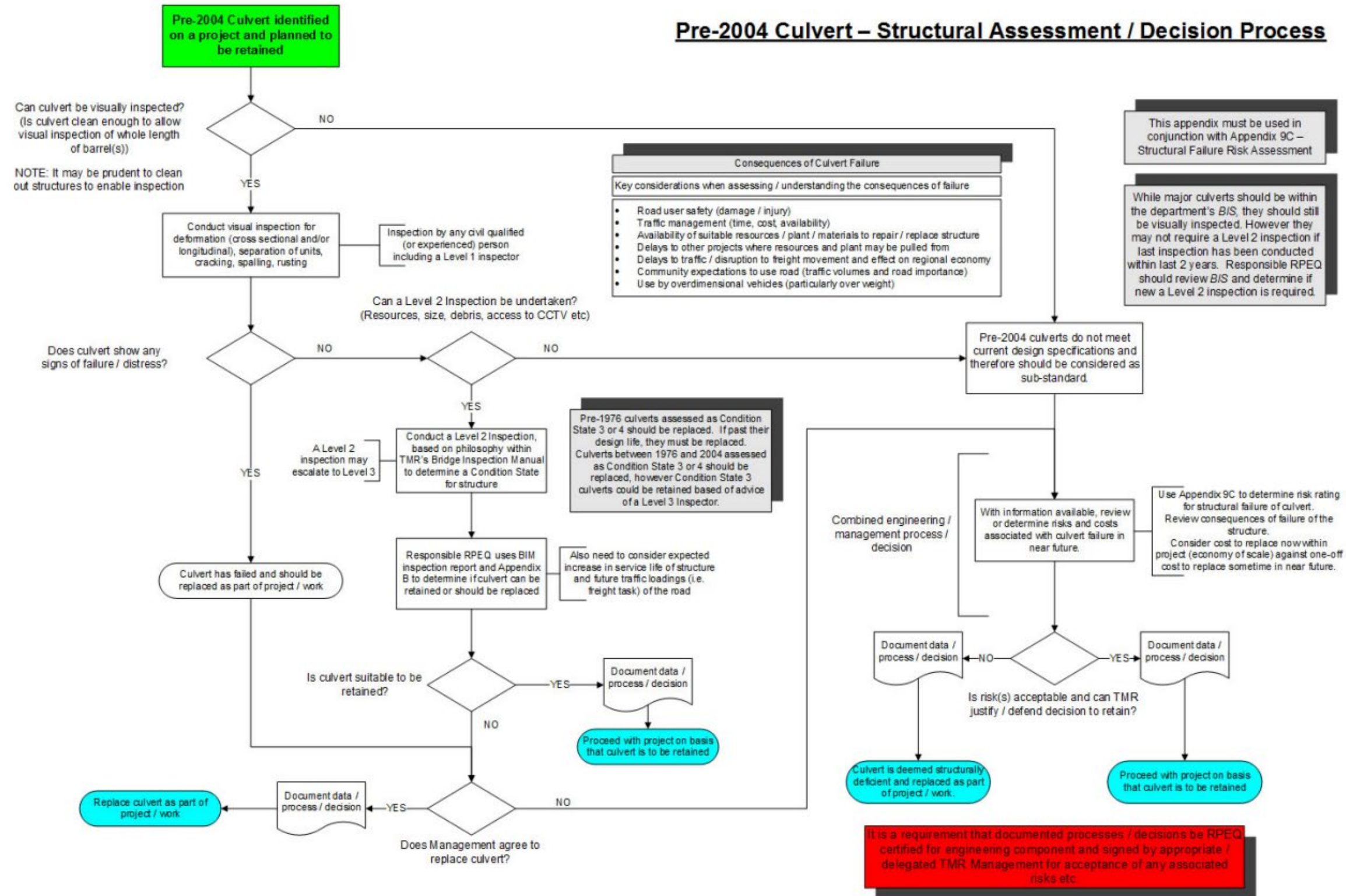

## Appendix G – Structural Failure Risk Assessment

### New

#### General

This appendix assesses the risk (probability) of structural failure in simple terms.

Culverts are categorised as either a ‘major culvert’ or a ‘minor culvert’. Major culverts are defined within the SIM. These structures are currently inspected on a regular basis with records stored in the department’s BIS. All other culverts are deemed minor culverts.

Link slab box culverts, cast-insitu culverts and arch culverts are not covered by this appendix and assessing risk of structural failure requires specialist advice.

#### Risk assessment – major culverts

For major culverts, a risk assessment can be undertaken using the ‘Whichbridge’ component within the BIS.

**Table G-1 – Risk rating – major**

Score	Risk	Recommended action
1500+	High	Replace structure
751–1500	Medium	Monitor structure
0–750	Low	No action required at this stage

#### Risk assessment – minor culverts

Risk of structural failure for minor culverts (under critical loading / cover is  $\leq 2$  m) is a function of:

- W – maximum horizontal dimension of a culvert (such as nominal diameter for circular culverts, nominal span width for box culverts), and
- C – depth of cover, which is defined as the minimum depth of material (under outer wheel path) from the road surface to top surface of culvert.

Note: When cover exceeds 2 m, inspection is still required, but specialist advice is required.

Assessment method is same for both single cell and multi-cell structures.

**Table G-2 – Risk rating – major**

Assessment criteria	Risk	Recommended action
When C is $\leq 600$ mm	High	Replace structure
All other situations	Low	No action required

**Table G-3 – Risk rating – W = 675 to 1200 mm**

Assessment criteria	Risk	Recommended action
When C is $\leq 600$ mm	High	Replace structure
When C is between 600 mm and W	Medium	Monitor structure
When C is $\geq W$	Low	No action required



**Table G-4 – Risk rating –  $W = 1350$  to  $1800$  mm\***

Assessment criteria	Risk	Recommended action
When C is $\leq W/2$	High	Replace structure
When C is between $W/2$ and $W$	Medium	Monitor structure
When C is $\geq W$	Low	No action required

Notes:

\*RCBCs greater than 1800 mm (in width) but less than 3.0 m<sup>2</sup> in waterway area are to be included.

These risk rating tables are combined and shown diagrammatically in Figure G.

**Figure G – Structural risk assessment – minor culverts**

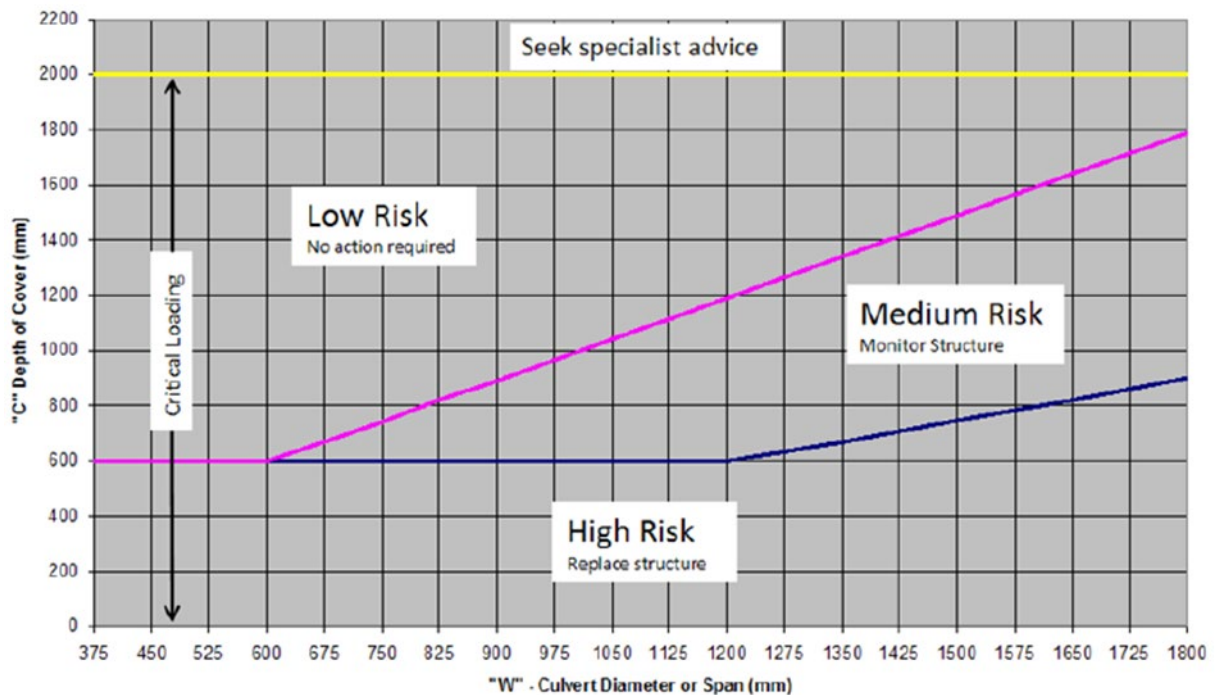



## Appendix H – Culvert Wingwall Length Calculations

**Table H-1 – Culvert description and symbols**

Description	Symbol
Internal diameter of a pipe culvert or internal height of a box culvert	D
Thickness of pipe or box culvert	T1
External diameter of pipe culvert or external height of box culvert	D2
Skew angle	$\phi$
Wingwall angle 1	$\alpha$
Wingwall angle 2	$\beta$
Batter slope	1 on S
Headwall thickness (typical value is 300 mm)	T2

Wingwall angles and lengths are shown in Figure H. The following steps are a guide for calculating the lengths of W1 and W2.

1. Calculate the culvert height.

$$\text{Culvert height} = D + T1$$

2. Find the horizontal distance of W1 perpendicular to the road alignment using the batter slope. Refer to Figure 9D Side Elevation – Wingwall.

$$W1 \text{ horizontal distance perpendicular to the road} = (D + T1) \times S - T2$$

3. Find the horizontal distance of W2 perpendicular to the road alignment using the batter slope. Refer to Figure 9D Side Elevation – Wingwall.

$$W2 \text{ horizontal distance perpendicular to the road} = (D + T1) \times S - T2 - (D2 - T1) \sin\phi$$

4. For square culverts, adjust W1 and W2 angles using the Figure 9D Wingwall Angles – Skew Culvert.

$$W1 \text{ angle} = \text{Skew angle} + \alpha \text{ from the table of angles}$$

$$W2 \text{ angle} = \text{Skew angle} - \beta \text{ from the table of angles}$$

5. Calculate W1.

$$W1 = [(D + T1) \times S - T2] \div \text{Cos}(\phi + \alpha)$$

6. For skew culverts, adjust the initial perpendicular calculation of W2 for the offset created by the part of the headwall that is square to the culvert cell. Check it is at least 1.5 x the culvert height. If 1.5 x (D + T1) is greater than the above horizontal distance, choose 1.5 x (D + T1) as the horizontal distance. Calculate W2.

$$W2 = \frac{\text{Horizontal distance from above}}{\cos(\phi - \beta)}$$

**Figure H – Culvert wingwall length calculations**

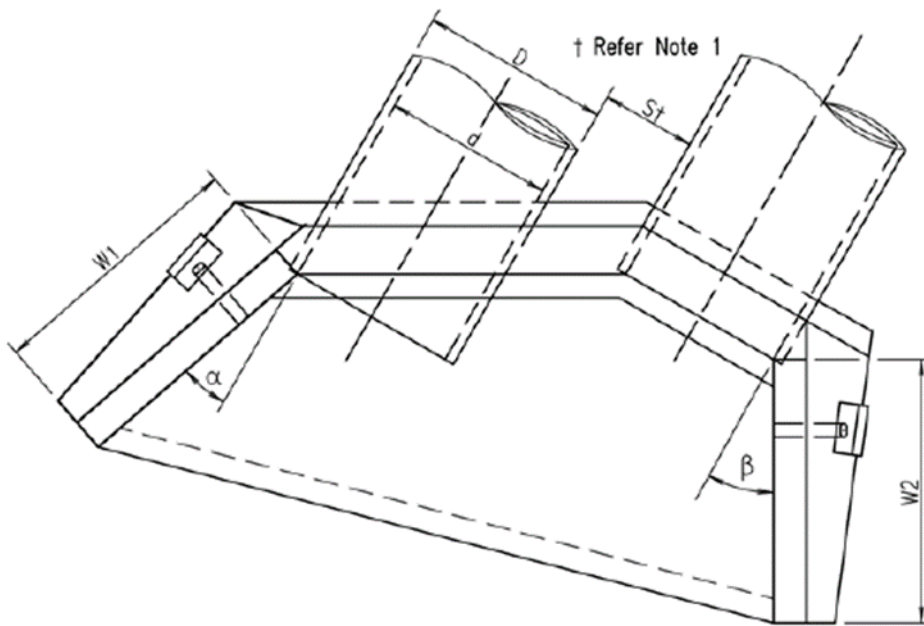

PLAN – MULTIPLE SKEW CULVERT

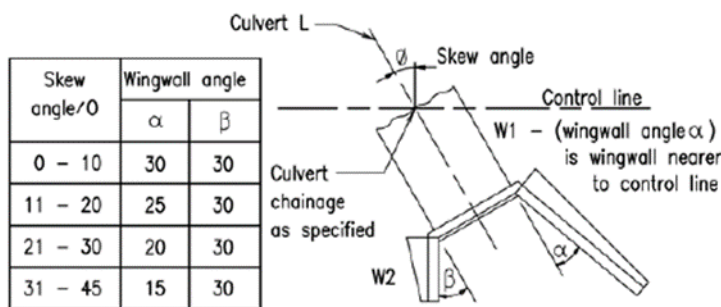

Skew angle/ $\theta$	Wingwall angle	
	$\alpha$	$\beta$
0 – 10	30	30
11 – 20	25	30
21 – 30	20	30
31 – 45	15	30

WINGWALL ANGLES – SKEW CULVERT  
Not to scale

